

Chateau LTE12



Chateau LTE12

The Chateau is a home router to be used with cellular network provider sim card.

Quickstart

Please follow these quick steps to set up your device:

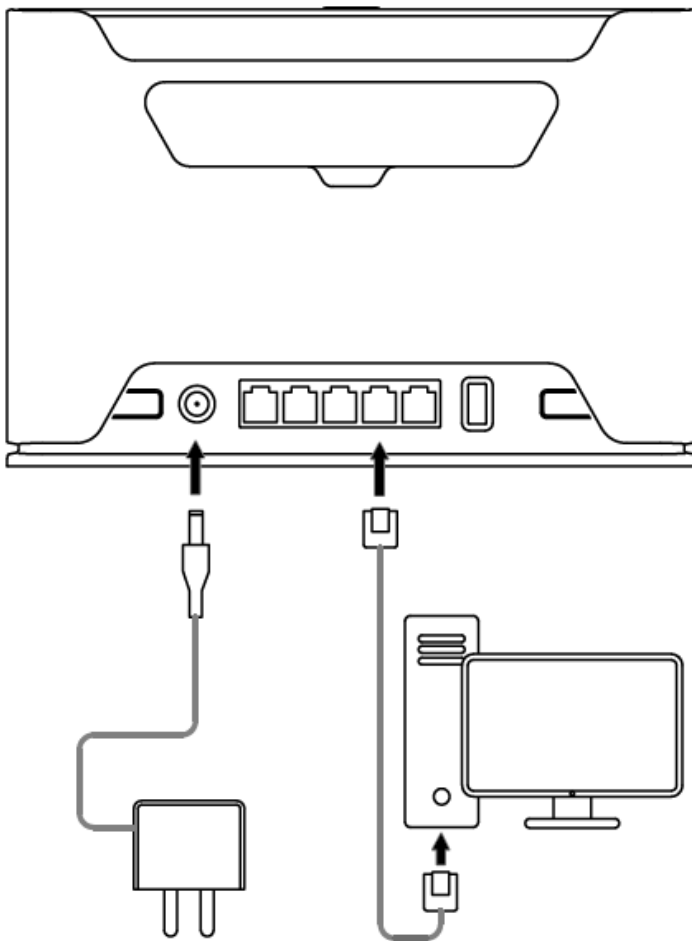

- Connect your computer to one of the Ethernet ports;
- Optional - Connect an external antenna to the SMA connector (The antennas are not provided in the package, see "[Chateau LTE12#Antenna usage](#)");
- Insert micro SIM card into the slot located under the device;

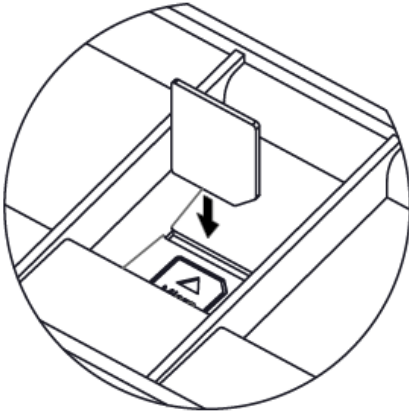

- Connect the power adapter to the DC jack;
- Once the device is powered on and PC connected to the device, open <https://192.168.88.1> in your web browser to start the configuration;
- User name: *admin* and there is no password by default you will be logged in automatically to the Quick Set screen;
- We recommend clicking the "Check for updates" button on the right side and updating your RouterOS software to the latest version to ensure the best performance and stability, Must have a valid SIM card inserted;
- To manually update the device, please go <https://mikrotik.com/download>
- Choose ARM packages for this device and download it to your PC.
- Upload downloaded packages to the WebFig "Files" menu and reboot the device.
- Updating your RouterOS software to the latest version will ensure the best performance, stability, and security updates.
- To personalize your wireless network, SSID can be changed in the fields "Network Name";
- Choose your country on the left side of the screen in the field "Country", to apply country regulation settings;
- Set up your wireless network password in the field "WiFi Password" the password must be at least eight symbols;
- Set up your router password in the bottom field "Password" to the right and repeat it in the field "Confirm Password", it will be used to login next time;
- Click on the "Apply Configuration" to save changes.

Connecting with a mobile app

Use your smartphone to access your router through WiFi.

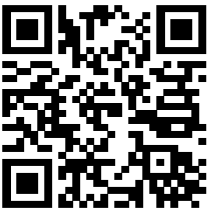

- Insert the SIM card and power on the device.
- Scan QR code with your smartphone and choose your preferred OS.
- Connect to the wireless network. SSID starts with MikroTik and has the last digits of the devices MAC address.
- Open application.
- By default, the IP address and user name will be already entered.
- Click Connect to establish a connection to your device through a wireless network.
- Choose Quick setup and application will guide you through all basic configuration settings in a couple of easy steps.
- An advanced menu is available to fully configure all necessary settings.

Expansion slots and ports

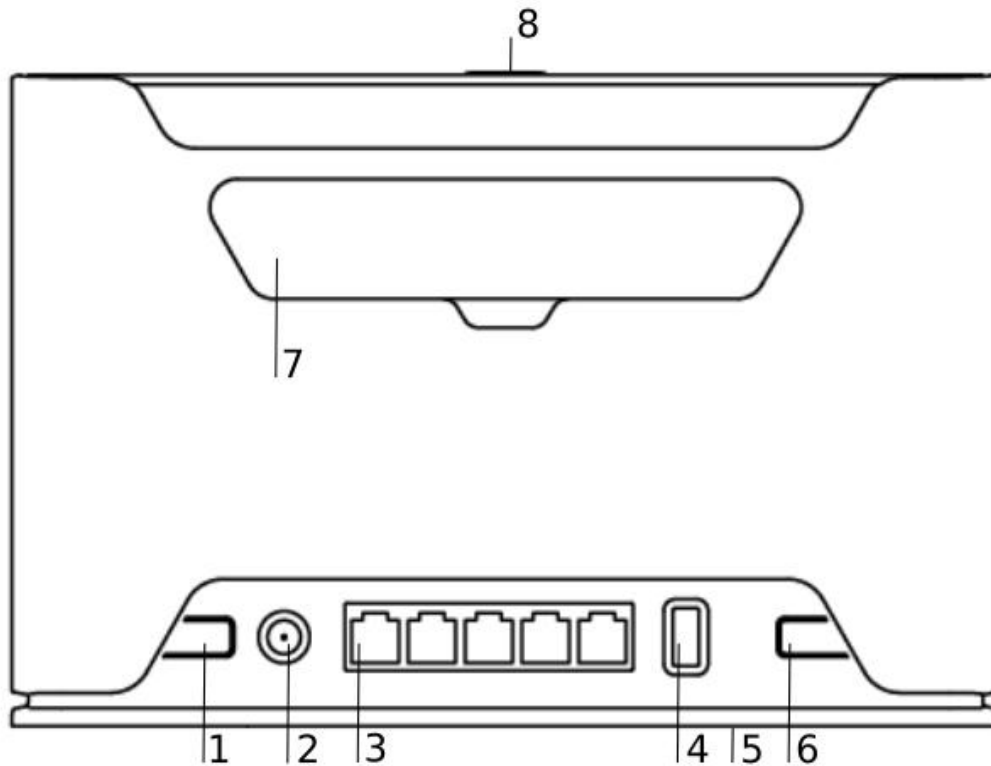

1. [Chateau LTE12#Reset button](#).
 2. [Chateau LTE12#Powering DC jack 2.0 mm](#).
 3. Five Gigabit ports, supporting automatic cross/straight cable correction (Auto MDI/X). Either straight or crossover cable can be used for connecting to other network devices.
 4. USB type-A.
 5. [SIM slot](#) for Micro sim card.
 6. Mode button.
 7. Cover for external [SMA antenna connectors](#).
 8. WPS [Sync button](#).
- Integrated Wireless module operating at 2.4 GHz, 802.11b/g/n protocol.
 - Integrated Wireless module operating at 5 GHz, 802.11a/n/ac protocol.

Mounting

The device is designed to be used indoors, by placing it on the desktop.

i We recommend using Cat5 shielded cable. When using and installing this device please pay attention to Maximum Permissible Exposure (MPE) safety distance with a minimum of 20 cm between the radiator and your body.

Powering

The device accepts power from an adapter:

- Direct-input power jack (5.5 mm outside and 2 mm inside, female, pin positive plug) 12-28 V DC.

The power consumption under maximum load can reach 17 W, with attachments 23 W.

Configuration

We recommend checking for updates frequently to receive the latest updates for your RouterOS software to ensure the best performance and stability. RouterOS includes many configuration options in addition to what is described in this document. We suggest starting here to get yourself accustomed to the possibilities: <https://mt.lv/help>. In case IP connection is not available, the Winbox tool (<https://mt.lv/winbox>) can be used to connect to the MAC address of the device from the LAN side (all access is blocked from the Internet port by default). For recovery purposes, it is possible to boot the device for reinstallation, see section [Chateau LTE12#Buttons and Jumpers](#).

Mode button

Mode button located on the back of the unit, to the right side (see "[Chateau LTE12#Expansion slots and ports](#)")
The Default configuration for the Mode button is dark mode - to turn off all LEDs. The button can be configured in RouterOS to run any user specified-scripts.

Sync button

Sync button located on the top of the unit. WPS Sync button, if configured on the wireless interface, can be used to connect new clients.



- Press and hold the WPS button for 1 – 5 seconds to enable WPS for wireless interfaces.

Front LED status

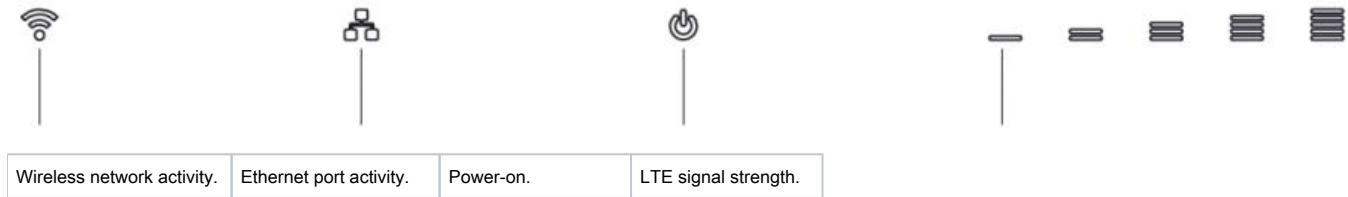

SIM slot usage



SIM card slot is designed to use with Micro SIM cards.
Nano SIM cards have different thickness, usage with adapter are not recommended.

Reset button

The reset button has three functions:

- Hold this button during boot time until LED light starts flashing, release the button to reset RouterOS configuration (total 5 seconds).
- Keep holding for 5 more seconds, LED turns solid, release now to turn on CAP mode. The device will now look for a CAPsMAN server (total 10 seconds).

- Or Keep holding the button for 5 more seconds until LED turns off, then release it to make the RouterBOARD look for Netinstall servers (total 15 seconds).

Regardless of the above option used, the system will load the backup RouterBOOT loader if the button is pressed before power is applied to the device. Useful for RouterBOOT debugging and recovery.

Netinstall

When performing Netinstall, make sure to use the latest v7 version of both ROS files and the Netinstall software.

Accessories

The package includes the following accessories that come with the device:

- EU/US Switching Power Supply 24 V , 1.2 A, 28.8 W, 86.8 % , VI, cable:150 cm.
- CAT5E UTP Flat Cable, 8P8C, AWG32, 1.5 m, white color.

Antenna usage

The device has two external antenna connectors on the back behind the doors.

- Open doors by pulling them upwards.
- Screw antenna to the SMA connector located on the left side. The maximum diameter for antennas connectors or any other adapters used is 13 mm.

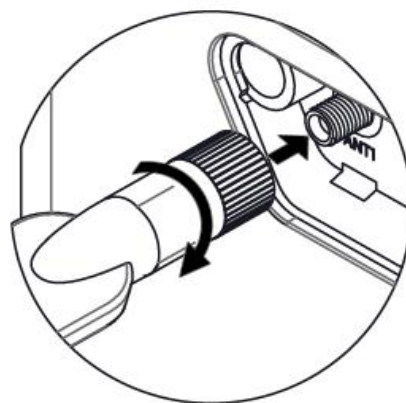
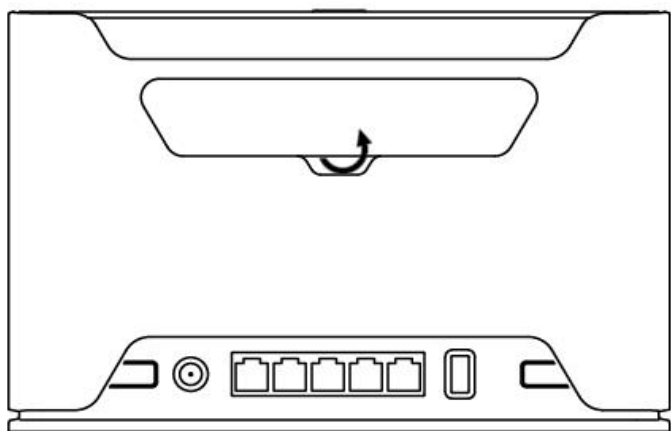

-  When using one antenna, please connect to the SMA connector on the left side (ANT1). Only when using two antennas, you can connect to the right SMA connector (ANT4).

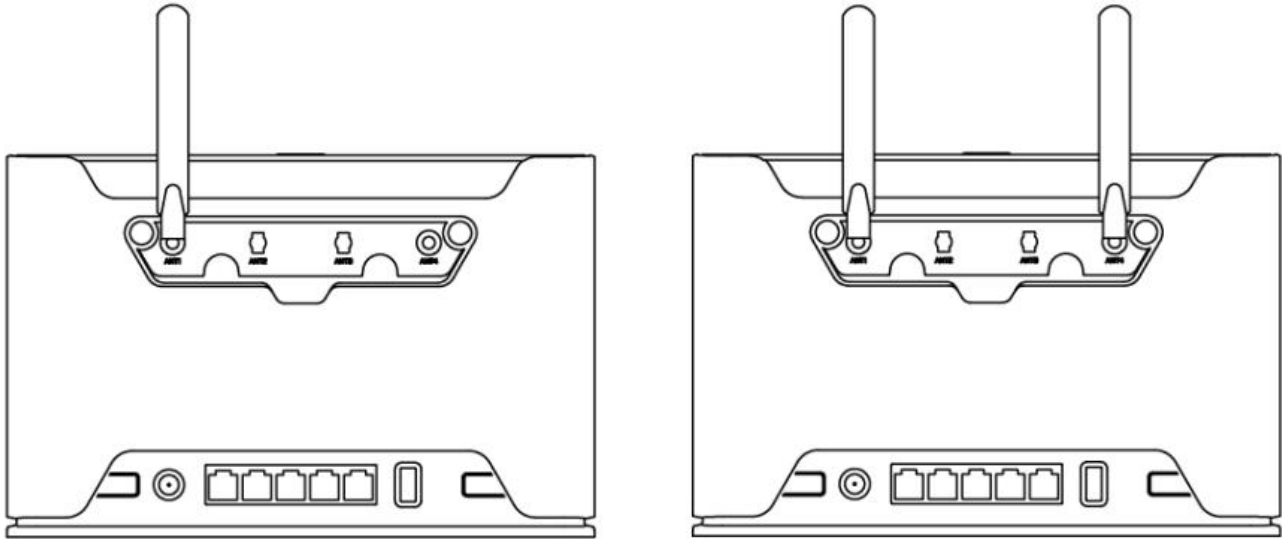

i Please connect and disconnect the antenna, when the device is turned off!
SMA connectors on the device are female.

We recommend using our antenna https://mikrotik.com/product/mant_lte_5o

Operating system support

The device supports RouterOS software version v7. The specific factory-installed version number is indicated in the RouterOS menu /system resource. Other operating systems have not been tested.

CE Declaration of Conformity

Manufacturer: Mikrotikls SIA, Brivibas gatve 214i Riga, Latvia, LV1039.

BG	С настоящото Mikrotikls SIA декларира, че този тип радиосъоръжение RouterBOARD е в съответствие с Директива 2014/53/ЕС. Цялостният текст на ЕС декларацията за съответствие може да се намери на следния интернет адрес: https://mikrotik.com/products
CS	Tímto Mikrotikls SIA prohlašuje, že typ rádiového zařízení RouterBOARD je v souladu se směrnicí 2014/53/EU. Úplné znění EU prohlášení o shodě je k dispozici na této internetové adrese: https://mikrotik.com/products
DA	Hermed erklærer Mikrotikls SIA, at radioudstyrstypen RouterBOARD er i overensstemmelse med direktiv 2014/53/EU. EU-overensstemmelseserklæringens fulde tekst kan findes på følgende internetadresse: https://mikrotik.com/products
DE	Hiermit erklärt Mikrotikls SIA, dass der Funkanlagentyp RouterBOARD der Richtlinie 2014/53/EU entspricht. Der vollständige Text der EU-Konformitätserklärung ist unter der folgenden Internetadresse verfügbar: https://mikrotik.com/products
EL	Με την παρούσα ο/η Mikrotikls SIA, δηλώνει ότι ο ραδιοεξοπλισμός RouterBOARD πληροί την οδηγία 2014/53/ΕΕ. Το πλήρες κείμενο της δήλωσης συμμόρφωσης ΕΕ διατίθεται στην ακόλουθη ιστοσελίδα στο διαδίκτυο: https://mikrotik.com/products

EN	<p>Hereby, Mikrotikls SIA declares that the radio equipment type RouterBOARD is in compliance with Directive 2014/53/EU. The full text of the EU declaration of conformity is available at the following internet address:</p> <p>https://mikrotik.com/products</p>
ES	<p>Por la presente, Mikrotikls SIA declara que el tipo de equipo radioeléctrico RouterBOARD es conforme con la Directiva 2014/53/UE. El texto completo de la declaración UE de conformidad está disponible en la dirección Internet siguiente:</p> <p>https://mikrotik.com/products</p>
ET	<p>Käesolevaga deklareerib Mikrotikls SIA , et käesolev raadioseadme tüüp RouterBOARD vastab direktiivi 2014/53/EL nõuetele. ELi vastavusdeklaratsiooni täielik tekst on kättesaadav järgmisel internetiaadressil:</p> <p>https://mikrotik.com/products</p>
FI	<p>Mikrotikls SIA vakuuttaa, että radiolaitetyyppi RouterBOARD on direktiivin 2014/53/EU mukainen. EU-vaatimustenmukaisuusvakuutuksen täysimittainen teksti on saatavilla seuraavassa internetosoitteessa:</p> <p>https://mikrotik.com/products</p>
FR	<p>Le soussigné, Mikrotikls SIA , déclare que l'équipement radioélectrique du type RouterBOARD est conforme à la directive 2014/53/UE. Le texte complet de la déclaration UE de conformité est disponible à l'adresse internet suivante:</p> <p>https://mikrotik.com/products</p>
HR	<p>Mikrotikls SIA ovime izjavljuje da je radijska oprema tipa RouterBOARD u skladu s Direktivom 2014/53/EU. Cjeloviti tekst EU izjave o sukladnosti dostupan je na sljedećoj internetskoj adresi:</p> <p>https://mikrotik.com/products</p>
HU	<p>Mikrotikls SIA igazolja, hogy a RouterBOARD típusú rádióberendezés megfelel a 2014/53/EU irányelvnek. Az EU-megfelelőségi nyilatkozat teljes szövege elérhető a következő internetes címen:</p> <p>https://mikrotik.com/products</p>
IT	<p>Il fabbricante, Mikrotikls SIA , dichiara che il tipo di apparecchiatura radio RouterBOARD è conforme alla direttiva 2014/53/UE. Il testo completo della dichiarazione di conformità UE è disponibile al seguente indirizzo Internet:</p> <p>https://mikrotik.com/products</p>
IS	<p>Hér með lýsir Mikrotikls SIA því yfir að RouterBOARD er í samræmi við grunnkröfur og aðrar kröfur, sem gerðar eru í tilskipun 2014/53/EU. Fullur texti ESB samræmisýfirlýsingar er að finna á eftirfarandi veffangi:</p> <p>https://mikrotik.com/products</p>
LT	<p>Aš, Mikrotikls SIA , patvirtinu, kad radijo įrenginių tipas RouterBOARD atitinka Direktyvą 2014/53/ES. Visas ES atitikties deklaracijos tekstas prieinamas šiuo interneto adresu:</p> <p>https://mikrotik.com/products</p>
LV	<p>Ar šo Mikrotikls SIA deklarē, ka radioiekārta RouterBOARD atbilst Direktīvai 2014/53/ES. Pilns ES atbilstības deklarācijas teksts ir pieejams šādā interneta vietnē:</p> <p>https://mikrotik.com/products</p>
MT	<p>B'dan, Mikrotikls SIA , niddikjara li dan it-tip ta' tagħmir tar-radju RouterBOARD huwa konformi mad-Direttiva 2014/53/UE. It-test kollu tad-dikjarazzjoni ta' konformità ta-UE huwa disponibbli f'dan l-indirizz ta-Internet li ġej:</p> <p>https://mikrotik.com/products</p>
NL	<p>Hierbij verklaar ik, Mikrotikls SIA , dat het type radioapparatuur RouterBOARD conform is met Richtlijn 2014/53/EU. De volledige tekst van de EU-conformiteitsverklaring kan worden geraadpleegd op het volgende internetadres:</p> <p>https://mikrotik.com/products</p>
NO	<p>Mikrotikls SIA erklærer herved at utstyret RouterBOARD er i samsvar med de grunnleggende krav og øvrige relevante krav i direktiv 2014/53/EU. Den fulle teksten til EU-samsvarserklæringen er tilgjengelig på følgende internetadresse:</p> <p>https://mikrotik.com/products</p>

PL	MikroTiks SIA niniejszym oświadcza, że typ urządzenia radiowego RouterBOARD jest zgodny z dyrektywą 2014/53/UE. Pełny tekst deklaracji zgodności UE jest dostępny pod następującym adresem internetowym: https://mikrotik.com/products
PT	O(a) abaixo assinado(a) MikroTiks SIA declara que o presente tipo de equipamento de rádio RouterBOARD está em conformidade com a Diretiva 2014/53/UE. O texto integral da declaração de conformidade está disponível no seguinte endereço de Internet: https://mikrotik.com/products
RO	Prin prezenta, MikroTiks SIA declară că tipul de echipamente radio RouterBOARD este în conformitate cu Directiva 2014/53/UE. Textul integral al declarației UE de conformitate este disponibil la următoarea adresă internet: https://mikrotik.com/products
SK	MikroTiks SIA týmto vyhlasuje, že rádiové zariadenie typu RouterBOARD je v súlade so smernicou 2014/53/EÚ. Úplné EÚ vyhlásenie o zhode je k dispozícii na tejto internetovej adrese: https://mikrotik.com/products
SL	MikroTiks SIA potrjuje, da je tip radijske opreme RouterBOARD skladen z Direktivo 2014/53/EU. Celotno besedilo izjave EU o skladnosti je na voljo na naslednjem spletnem naslovu: https://mikrotik.com/products
SV	Härmed försäkrar MikroTiks SIA att denna typ av radioutrustning RouterBOARD överensstämmer med direktiv 2014/53/EU. Den fullständiga texten till EU-försäkran om överensstämmelse finns på följande webbadress: https://mikrotik.com/products

MPE statement

This equipment complies with EU radiation exposure limits set forth for an uncontrolled environment. This equipment should be installed and operated with minimum distance of 20 cm between the radiator and your body, unless specifically stated otherwise in page 1 of this document. In RouterOS you must specify your country, to make sure local wireless regulations are observed.

Frequency bands terms of use

Frequency range (for applicable models)	Channels used	Maximum Output Power (EIRP)	Restriction
2412-2472 MHz	1 - 13	20 dBm	Without any restriction to use in all EU Member States
5150-5250 MHz	26 - 48	23 dBm	Restricted to indoor use only*
5250-5350 MHz	52 - 64	20 dBm	Restricted to indoor use only*
5470-5725 MHz	100 - 140	27 dBm	Without any restriction to use in all EU Member States

* It is the customer's responsibility to follow local country regulations, including operation within legal frequency channels, output power, cabling requirements, and Dynamic Frequency Selection (DFS) requirements. All MikroTik radio devices must be professionally installed!

Note. The information contained here is subject to change. Please visit the product page on www.mikrotik.com for the most up to date version of this document.



BG. Инструкции: Свържете адаптера на захранване, за да включите устройството. Отворете 192.168.88.1 в уеб браузър, за да настроите продукта. Повече информация в [+}https://mt.lv/help-bg](https://mt.lv/help-bg)

CS. Návod k použití: Připojte napájecí adaptér k zapnutí přístroje. Otevřete 192.168.88.1 ve webovém prohlížeči pro konfiguraci produktu. Více informací najdete v [+}https://mt.lv/help-cs](https://mt.lv/help-cs)

DA. Instruktionsbog: Tilslut strømadapteren for at tænde for enheden. Åbn 192.168.88.1 i en webbrowser til at konfigurere produktet. Mere information i [+}https://mt.lv/help-da](https://mt.lv/help-da)

DE. Bedienungsanleitung: Verbinden Sie das Netzteil, um das Gerät einzuschalten. Öffnen Sie 192.168.88.1 in einem Web-Browser, um das Produkt zu konfigurieren. Weitere Informationen im [+}https://mt.lv/help-de](https://mt.lv/help-de)

EL. εγχειρίδιο οδηγιών: Συνδέστε τον προσαρμογέα τροφοδοσίας για να ενεργοποιήσετε τη μονάδα. Ανοίξτε 192.168.88.1 σε ένα πρόγραμμα περιήγησης στο Web για να διαμορφώσετε το προϊόν. Περισσότερες πληροφορίες στο [+}https://mt.lv/help-el](https://mt.lv/help-el)

EN. Instruction manual: Connect the power adapter to turn on the device. Open 192.168.88.1 in your web browser, to configure it. More information on [+}https://mt.lv/help-en](https://mt.lv/help-en)

[tps://mt.lv/help+](https://mt.lv/help+)

ES. Manual de instrucciones: Conecte el adaptador de alimentación para encender la unidad. Abra 192.168.88.1 en un navegador web para configurar el producto. Más información en [{}https://mt.lv/help-es+](https://mt.lv/help-es+)

ET. Kasutusjuhend: Ühendage toiteadapter seadme sisselülitamiseks. Avatud 192.168.88.1 in veebilehitseja seadistada toodet. Rohkem teavet [{}https://mt.lv/help-et+](https://mt.lv/help-et+)

FI. Käyttöohje: Kytke virtalähde päälle laitteen. Avaa 192.168.88.1 in selaimen määrittää tuotteen. Lisää tietoa [{}https://mt.lv/help-fi+](https://mt.lv/help-fi+)

FR. Mode d'emploi: Connectez l'adaptateur d'alimentation pour allumer l'appareil. Ouvrez 192.168.88.1 dans un navigateur Web pour configurer le produit. Plus d'informations dans [{}https://mt.lv/help-fr+](https://mt.lv/help-fr+)

HR. Uputa za uporabu: Priključite napajanje i uključite uređaj. Za konfiguraciju uređaja u pregledniku otvorite 192.168.88.1. Više informacija je na [{}https://mt.lv/help-hr+](https://mt.lv/help-hr+)

HU. Használati utasítás: Csatlakoztassa a hálózati adaptert a készülék bekapcsolásához. Megnyitása 192.168.88.1 egy webböngészőben beállítani a terméket. Több információ [{}https://mt.lv/help-hu+](https://mt.lv/help-hu+)

IT. Manuale di istruzioni: Collegare l'adattatore di alimentazione per accendere l'unità. Aprire 192.168.88.1 in un browser Web per configurare il prodotto. Maggiori informazioni in [{}https://mt.lv/help-it+](https://mt.lv/help-it+)

IS. Notkunarlíðbeiningar: Tengdu straumbreytinn til að kveikja á tækinu. Opnaðu 192.168.88.1 í vafra til að stilla það. Nánari upplýsingar á [{}https://mt.lv/help-is+](https://mt.lv/help-is+)

NO. Instruksjonsmanual: Koble strømadapteren for å slå på enheten. Åpne 192.168.88.1 i nettleseren din for å konfigurere den. Mer informasjon på [{}https://mt.lv/help-no+](https://mt.lv/help-no+)

LT. Naudojimosi instrukcija: Prijunkite maitinimo adapterį įjunkite įrenginį. Į interneto naršyklę 192.168.88.1 Atidarykite galite konfigūruoti gaminį. Daugiau informacijos rasite [{}https://mt.lv/help-lt+](https://mt.lv/help-lt+)

LV. Lietošanas instrukcija: Pievienojiet Strāvas adapteri, lai ieslēgtu ierīci. Atvērt 192.168.88.1 ar interneta pārlūku, lai konfigurētu produktu. Plašāka informācija [{}https://mt.lv/help-lv+](https://mt.lv/help-lv+)

MT. Manwal tal-istruzzjoni: Qabbad l-adapter tal-qawwa biex iddawwar it-tagħmir. Iftaħ 192.168.88.1 fil-web browser tiegħek, biex jiġi kkonfiguratur. Aktar informazzjoni fuq [{}https://mt.lv/help-mt+](https://mt.lv/help-mt+)

NL. Handleiding: Sluit voedingsadapter aan op het apparaat in te schakelen. Open 192.168.88.1 in een webbrower om het product te configureren. Meer informatie in [{}https://mt.lv/help-nl+](https://mt.lv/help-nl+)

PL. Instrukcja obsługi: Podłącz adapter zasilania, aby włączyć urządzenie. Otwórz 192.168.88.1 w przeglądarce internetowej, aby skonfigurować urządzenie. Więcej informacji w [{}https://mt.lv/help-pl+](https://mt.lv/help-pl+)

PT. Manual de instruções: Conecte o adaptador de alimentação para ligar o aparelho. Abra 192.168.88.1 em um navegador da web para configurar o produto. Mais informações em [{}https://mt.lv/help-pt+](https://mt.lv/help-pt+)

RO. Instrucțiuni de utilizare: Conectați adaptorul de alimentare pentru a porni aparatul. Deschide 192.168.88.1 într-un browser web pentru a configura produsul. Mai multe informații în [{}https://mt.lv/help-ro+](https://mt.lv/help-ro+)

SK. Navodila: Priključite napajalnik za vklop naprave. Odprite 192.168.88.1 v spletnem brskalniku nastaviti izdelek. Več informacij v [{}https://mt.lv/help-sk+](https://mt.lv/help-sk+)

SL. Návod na použítie: Pripojite napájací adaptér k zapnutiu prístroja. Otvorte 192.168.88.1 vo webovom prehliadači pre konfiguráciu produktu. Viac informácií nájdete v [{}https://mt.lv/help-sl+](https://mt.lv/help-sl+)

SV. Instruktionsmanual: Anslut nätadaptern för att slå på enheten. Öppna 192.168.88.1 i en webbläsare för att konfigurera produkten. Mer information på [{}https://mt.lv/help-sv+](https://mt.lv/help-sv+)

NO. Bruksanvisningen: Koble strømadapteren for å slå på enheten. Åpne 192.168.88.1 i en nettleser for å konfigurere produktet. Mer informasjon på [{}https://mt.lv/help-no+](https://mt.lv/help-no+)

RU. Руководство по эксплуатации: подключите адаптер питания чтобы включить устройство. Откройте 192.168.88.1 в своем веб-браузере для конфигурации. Дополнительная информация <https://mt.lv/help-ru>

CN. 说明书。 连接电源适配器以打开设备。在Web浏览器中打开192.168.88.1进行配置。有关[{}https://mt.lv/help-zh+](https://mt.lv/help-zh+)的更多信息

UA. Керівництво з експлуатації: підключіть адаптер живлення щоб увімкнути пристрій. Відкрийте 192.168.88.1 в своєму веб-браузері для конфігурації. Додаткова інформація: [{}https://mt.lv/help-ua+](https://mt.lv/help-ua+)